

# EASYGATE ELITE

STYLISH. DISCREET. FLEXIBLE.

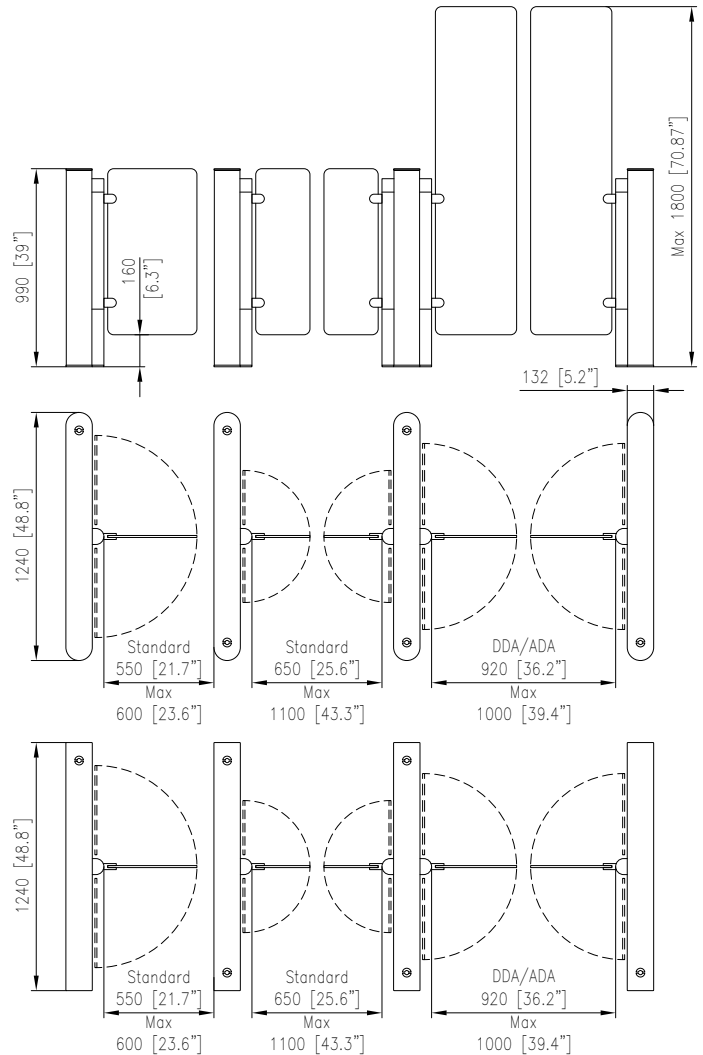

## AT A GLANCE

- Available in rounded cabinet
- Barrier opening time from 0.7 seconds
- Customisable finishes
- DDA Compliant

## SPECIFICATIONS

### DIMENSIONS

<b>Standard:</b>	1240mm(L) x 132mm(W) x 990mm(H)
<b>Barrier Height:</b>	990mm – 1800mm
<b>Lane width:</b>	550mm – 1100mm (customisable)
<b>Gap Between barriers:</b>	50mm
<b>MBTF:</b>	3,000,000 operations
<b>Warranty:</b>	24 months
<b>Sensors:</b>	Up to 26 sensor pairs
<b>Power Supply Input:</b>	230 volts
<b>Control Electronics:</b>	12 V DC
<b>Current:</b>	Standby 0.4 A
<b>Consumption:</b>	Operational 6 A

<b>Operating Temp:</b>	10°C to 50°C (with heater)
<b>Motor:</b>	12 V DC
<b>Operation Mode:</b>	Normally Closed
<b>Control:</b>	Card In / Card Out Card In / No Exit Card In / Free Exit Locked Free Passage
<b>Pictograms:</b>	Wait Mode (White Indicator) Access Granted (Green Indicator) Illegal Transaction (Red Indicator)
<b>Barrier Opening Time (Standard lane):</b>	0.7 Seconds
<b>MATERIALS</b>	
<b>Top Cover:</b>	8mm Smoked Glass (other options)
<b>Front Cover:</b>	Black RAL
<b>Side Panels:</b>	Black RAL
<b>Frame:</b>	Steel

Specifications subject to change without prior notice.